

## DV: Throttle Body Assembly Electronic Throttle Control (ETC)

[DV: Pinpoint Tests](#) →

### Introduction



**WARNING: SUBSTANTIAL OPENING AND CLOSING TORQUE IS APPLIED BY THIS SYSTEM. TO PREVENT INJURY, BE CAREFUL TO KEEP FINGERS AWAY FROM THROTTLE MECHANISM WHEN ACTUATED. FAILURE TO FOLLOW THESE INSTRUCTIONS MAY RESULT IN PERSONAL INJURY.**

**Note:** The voltage of the TP2 circuit and PID reaches a limit of approximately 4.5 volts at approximately 45 degrees of throttle angle.

This pinpoint test is intended to diagnose the following:

- electronic throttle body (ETB) (9F991)
- electronic throttle body throttle position sensor (ETBTPS) (9E928)
- harness circuits: ETCRTN, ETCREF, TP1, TP2, TACM+, and TACM-
- powertrain control module (PCM) (12A650)

### Electronic Throttle Body Throttle Position Sensor (ETBTPS) Connector

A

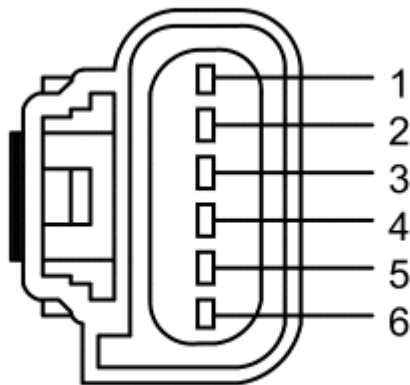

A0077520

B

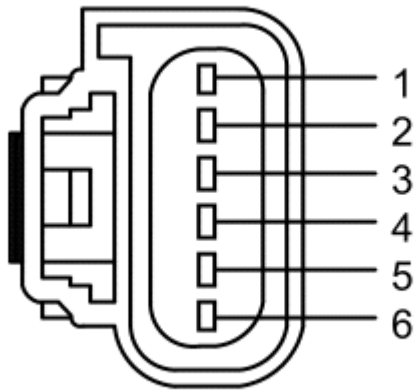

A0094772

C

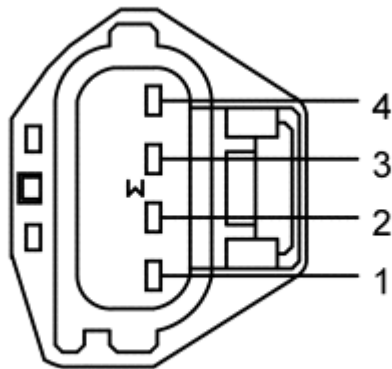

A0077519

Vehicle	Connector	Pin	Circuit
E-Series 4.6L, Edge, F-150 2V 4.6L, Flex, Focus, MKS, MKX, MKZ, Sable, Taurus, Taurus X	A	4 1 2 3	TP2 TP1 ETCRTN  ETCREF
Escape / Mariner,  F-150 3V 4.6L, Fusion 3.0L, Milan 3.0L	B	6 3 4 5	TP2 TP1 ETCRTN  ETCREF
Fusion 2.3L, Milan 2.3L	B	4 6 3	TP2 TP1 ETCRTN

		5	ETCREF
All other vehicles	C	1 4 3 2	TP2 TP1 ETCRTN ETCREF

### Electronic Throttle Body Throttle Actuator Control Motor (ETBTACM) Connector

A

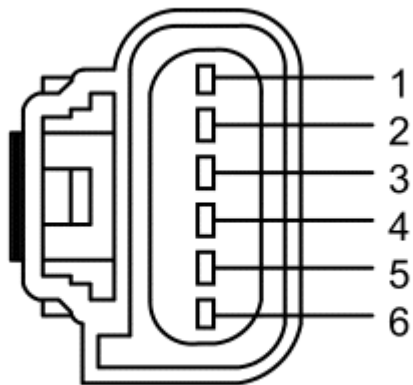

A0077520

B

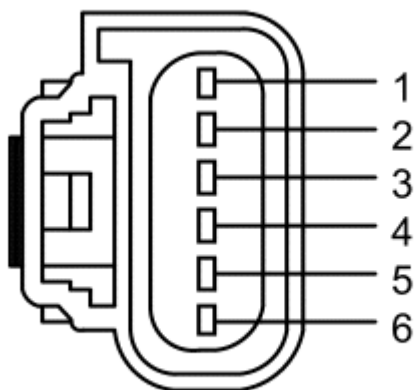

A0094772

C

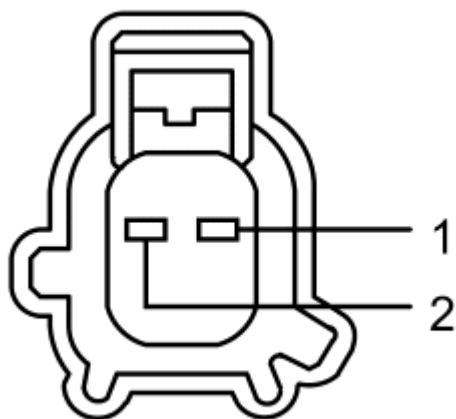

A0077510

Vehicle	Connector	Pin	Circuit
E-Series 4.6L, Edge, F-150 2V 4.6L, Flex, Focus, MKS, MKX, MKZ, Sable, Taurus, Taurus X	A	6 5	TACM- TACM+
Escape / Mariner, F-150 3V 4.6L, Fusion 2.3L, Milan 2.3L	B	2 1	TACM- TACM+
Fusion 3.0L, Milan 3.0L	B	1 2	TACM- TACM+
All other vehicles	C	2 1	TACM- TACM+

## Powertrain Control Module (PCM) Connector

For PCM connector views or reference values, refer to [Section 6](#).

Vehicle	Connector	Pin	Circuit
Crown Victoria, Explorer, Explorer SportTrac, Grand Marquis, Mountaineer, Town Car	170 PIN	B24, B4, E66 B43, B6, E59 B35 B47 E51 E34 E60 E61	ETCREF ETCRTN VPWR PWRGND  TACM- TACM+ TP2 TP1

E-Series 4.6L, E-Series 5.4L, Expedition, F-150, Navigator	190-PIN	E59 E60 B67 B22 E51 E34 E45 E44	ETCREF ETCRTN VPWR PWRGND  TACM- TACM+ TP2 TP1
E-Series 6.8L, F-Series Super Duty	170 PIN	B16, B4, E66 B18, B6, E59 B35 B47 E51 E34 E60 E61	ETCREF ETCRTN VPWR PWRGND  TACM- TACM+ TP2 TP1
Escape / Mariner	190-PIN	E57 E61 B67 B69 E51 E34 E58 E41	ETCREF ETCRTN VPWR PWRGND  TACM- TACM+ TP2 TP1
Focus	190-PIN	E59 E60 B67 B69 E51 E34 E45 E44	ETCREF ETCRTN VPWR PWRGND  TACM- TACM+ TP2 TP1
Fusion, Milan, MKZ	140 PIN	B21, B28, E66  B59, B60, E59  B51 B67 E51 E34 E60 E61	ETCREF ETCRTN VPWR PWRGND  TACM- TACM+ TP2 TP1
Mustang	170 PIN	B24, B4, E66 B41, B6, E59 B35 B47 E51 E34 E60 E61	ETCREF ETCRTN VPWR PWRGND  TACM- TACM+ TP2 TP1
All other vehicles	190-PIN	B21, B28, E66  B59, B65, E59  B51 B67 E51 E34	ETCREF ETCRTN VPWR PWRGND  TACM- TACM+ TP2

		E60 E61	TP1
--	--	------------	-----

DV: Pinpoint Tests →

---